

**ATTREZZATURE
PER VEICOLI INDUSTRIALI**

HEAVY VEHICLES EQUIPMENT
EQUIPEMENTS POUR POIDS LOURDS
GERÄTE FÜR LKW-REPARATUREN

Made in Italy 

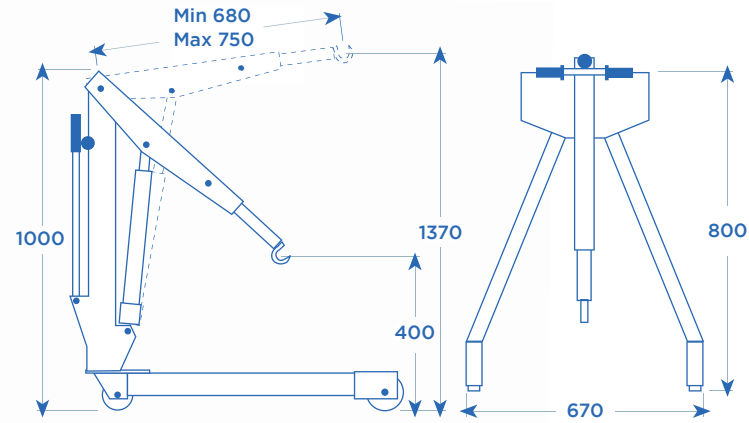
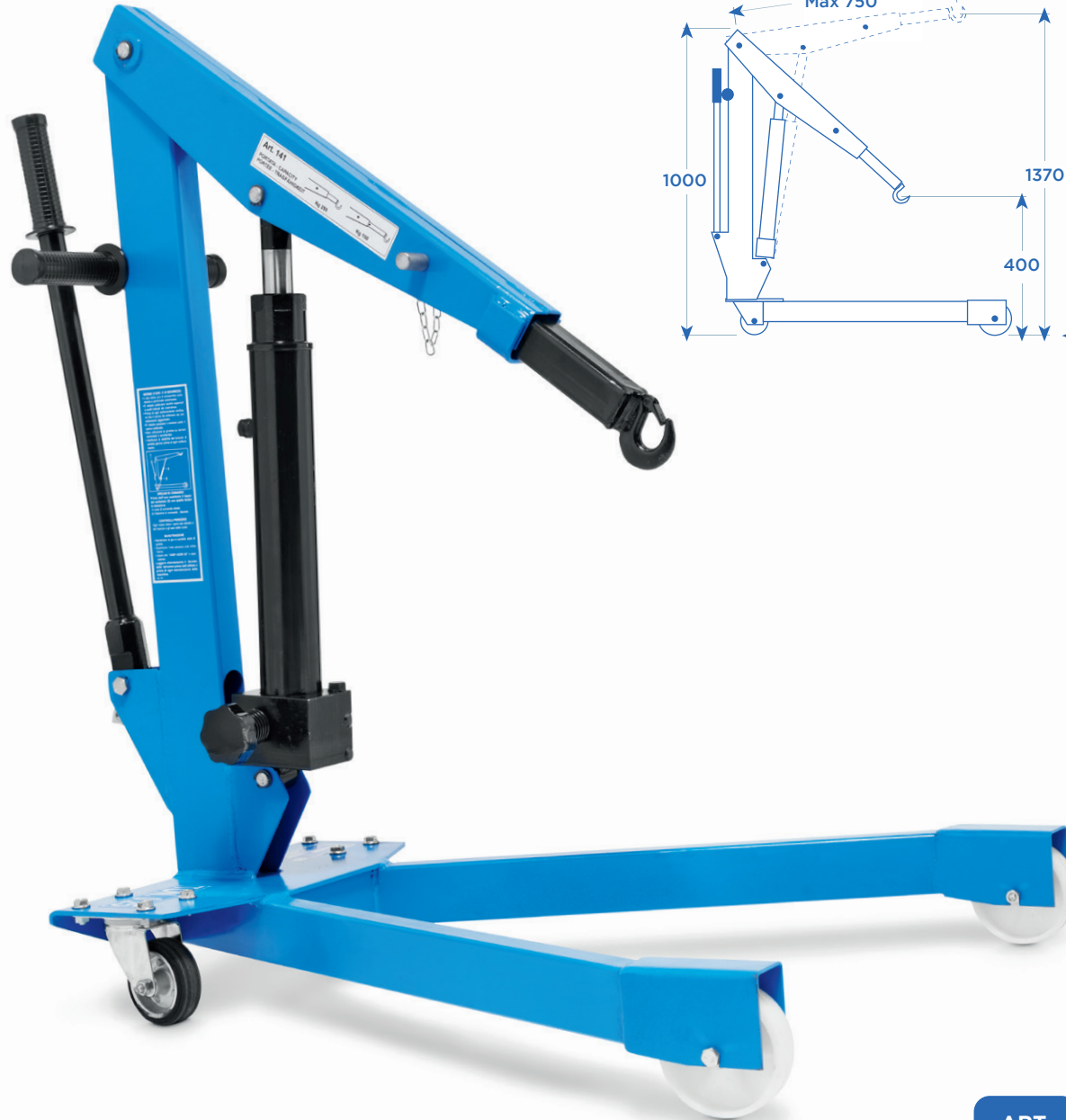

ART. 141

Gru idraulica per stacco e riattacco balestre.

Corredata di attacco a due catene per un rapido aggancio delle balestre.

Hydraulic crane to detach and reattach leaf springs. It is fitted with hook and two chains to clasp the leaf spring quickly.

Grue hydraulique pour détacher et rattacher les ressorts de suspension. Elle est équipée de crochet à deux chaînes pour un accrochage rapide du ressort de suspension.

Hydraulikkran zum Aus- und Einbau von Blattfedern. Die Aufhängung ist mit 2 Ketten ausgestattet, wodurch ein rasches Aufhängen der Federn möglich ist. Bedienung mit Handpumpe.







ART. 141

168

ART.		
141	250 kg	150 kg



ART.					
243	1000 Kg	1080	650	260	960
243/A	1500 kg	1080	650	260	960

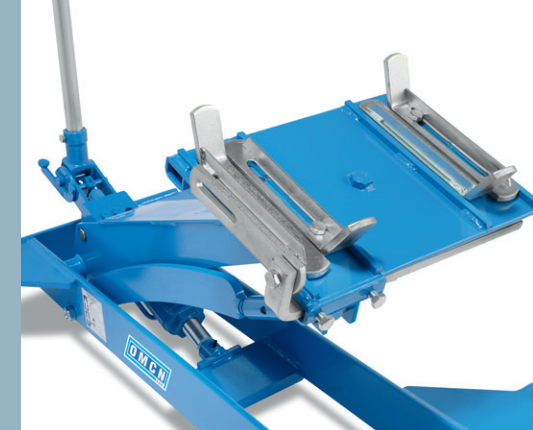

ART. 243/A

TRACCIATO TECNICO COSTRUTTIVO

- Sollevatore idraulico per smontaggio e montaggio dei cambi e dei differenziali.
- Dotato di piattaforma orientabile e regolabile tramite braccio a vite.
- Robusta struttura in acciaio saldato.
- Comando di discesa "uomo presente".
- Dotato di valvola di protezione contro i sovraccarichi.
- Le quattro ruote girevoli garantiscono un posizionamento preciso.
- Ruote in poliuretano (Art. 243).
- Ruote in acciaio (Art. 243/A).

TECHNICAL AND STRUCTURAL LAY-OUT

- Hydraulic jack to mount and dismount gearboxes and differential gears.
- Adjustable platform through a screw.
- Compact structure made of welded steel.
- "Man standing-by" descent control device.
- Safety valve to avoid any possible overload.
- Four turning wheels to guarantee a precise positioning.
- Wheels made of polyurethane (Art. 243).
- Wheels made of steel (Art. 243/A).

RELEVÉ TECHNIQUE

- Elévateur hydraulique à monter et démonter les boîtes de vitesse et les différentiels.
- Plateforme orientable réglable par bras à vis.
- Structure compacte en acier soudé.
- Commande de descente de type "homme-mort".
- Soupape de sécurité anti-surcharge.
- Quatre roues pivotantes pour un positionnement très précis.
- Roues en polyuréthane (Art. 243).
- Roues en acier (Art. 243/A).

TECHNISCHE UND KONSTRUKTIVE ANGABEN

- Hydraulisch Rangierheber für die Aus- und Einbau von LKW-Differentialgetrieben.
- Mit einer schwenkbaren Plattform, die dank einer Schraubenwinde verstellbar ist.
- Kompakte Struktur aus geschweißtem Stahl.
- Totmann- Abstiegskontrolle.
- Überlastventil gegen jeder Überlastung.
- Mit vier lenkbaren Rädern, die eine genaue Lagerung sichern.
- Polyurethanrädern (Art. 243).
- Stahlrädern (Art. 243/A).

ART. 388/B

Attrezzo universale per smontaggio, rimontaggio e movimentazione ruote dei veicoli pesanti. Particolarmente indicato per una centratura rapida e pratica dei bulloni in fase di montaggio. Indispensabile per camionisti in caso di foratura.

Universal tool for the disassembling, reassembling and moving of heavy vehicles' wheels. Particularly suited for a fast and practical centring of the bolts during the assemblage phase. Indispensable for lorry-drivers in case of puncture.

Outil universel à démonter, remonter et déplacer les roues de poids lourds. Particulièrement indiqué pour le centrage rapide et pratique des boulons en phase de montage. Indispensable aux camionneurs en cas de crevaison d'un pneu

Gerät zur Montage und Demontage sowie den Transport von LKW-Reifen. Speziell geeignet für ein schnelles Zentrieren der Radbolzen bei der Montage. Unentbehrliches Gerät im Falle eines Reifenschadens.

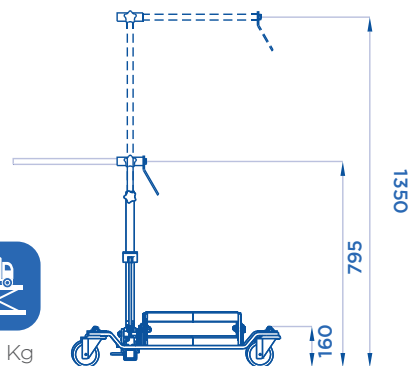
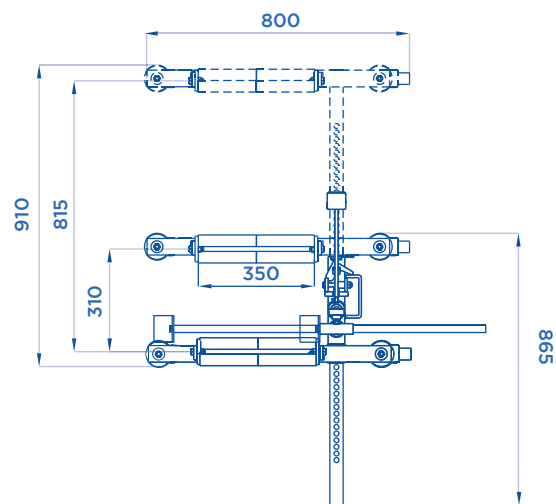

ART.

388/B



200 Kg



ART. 227/A

Apparecchio a funzionamento idraulico per operare su pesanti automezzi per lo smontaggio e montaggio di ruote semplici e gemellari, con comando sia a mano che a pedale. Completo di 4 ruote girevoli e doppi rulli a cuscinetti sui bracci di sollevamento.

Bracci regolabili in senso trasversale e reclinabili onde facilitare l'operazione di centratura dei fori.

Hydraulic functioning apparatus which operates on heavy vehicles to disassemble simple and twin wheels. It has a hand and foot-lever control. It is equipped with 4 turning wheels and double rolls with bearings on hoisting arms.

The arms are adjustable in transversal directions and reclining, in order to make the hole centering easier.

Elévateur hydraulique à monter et démonter les roues simples ou jumelées des poids lourds, avec commande manuelle et à pédale. Equipé de 4 roues pivotantes et de double rouleaux sur les bras de levage.

Bras réglables dans le sens transversal et inclinables, afin de faciliter le centrage des trous des jantes.

Hydraulik-Gerät für die Arbeit an schweren Fahrzeugen. Geeignet zur Demontage und Montage einzelner Reifen sowie Zwillingsreifen. Sowohl Hand-als auch Pedalbedienung. Ausgestattet mit lenkbaren Rädern und Tragarmen mit doppelten, kugelgelagerten Rollen.

Zusätzliches Neigen des Lifts möglich, um das genaue Zentrieren des Rades zu erleichtern.

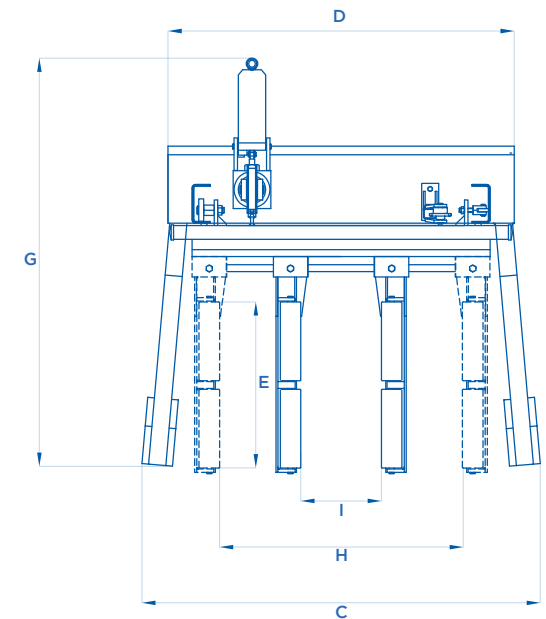
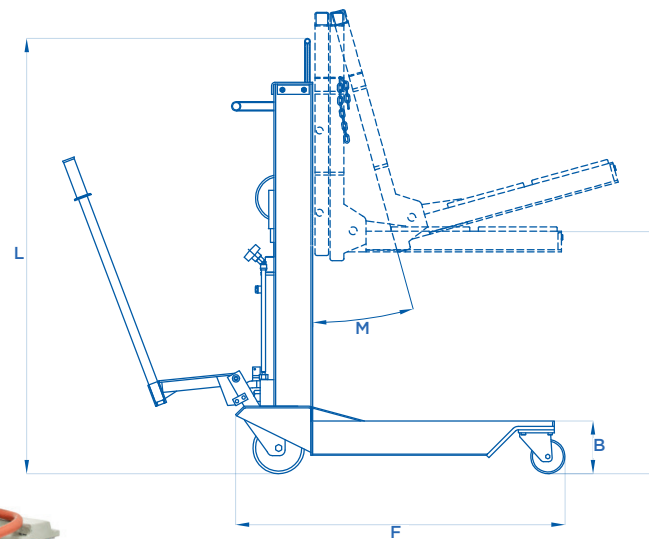
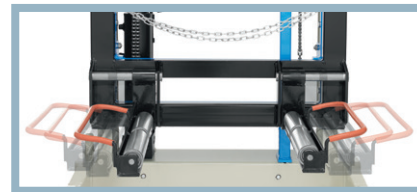
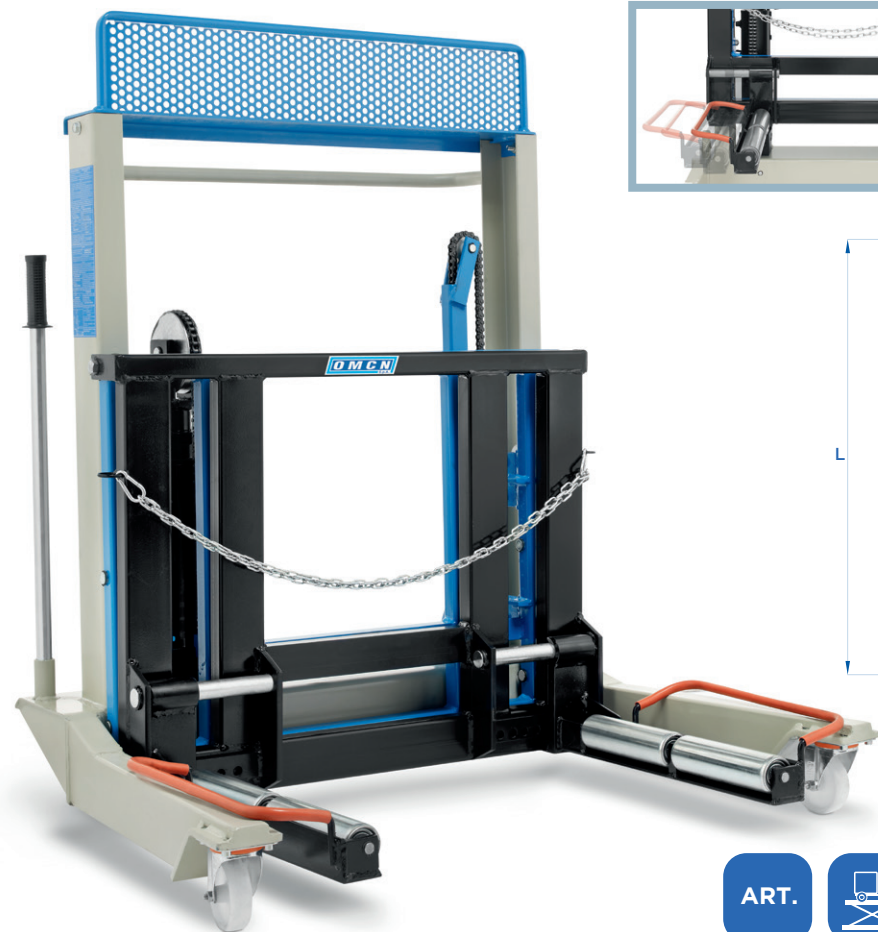

ART. 227/A

ART.		A mm	B mm	C mm	D mm	E mm	F mm	G mm	H mm	I mm	L mm	M α
227/A	700 kg	650	160	1150	1000	490	920	1150	740	470	1410	10°

MAXI

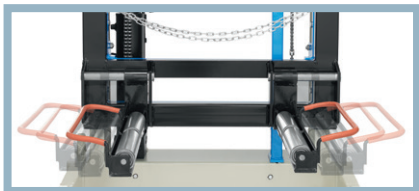

ART. 227/B

Apparecchio a funzionamento idraulico per operare su pesanti automezzi per lo smontaggio e montaggio di ruote semplici e gemellari, con comando sia a mano che a pedale. Completo di 4 ruote girevoli e doppi rulli a cuscinetti sui bracci di sollevamento.

Bracci regolabili in senso trasversale e reclinabili onde facilitare l'operazione di centratura dei fori.

Hydraulic functioning apparatus which operates on heavy vehicles to disassemble simple and twin wheels. It has a hand and foot-lever control. It is equipped with 4 turning wheels and double rolls with bearings on hoisting arms.

The arms are adjustable in transversal directions and reclining, in order to make the hole centering easier.

Elévateur hydraulique à monter et démonter les roues simples ou jumelées des poids lourds, avec commande manuelle et à pédale. Equipé de 4 roues pivotantes et de double rouleaux sur les bras de levage.

Bras réglables dans le sens transversal et inclinables, afin de faciliter le centrage des trous des jantes.

Hydraulik-Gerät für die Arbeit an schweren Fahrzeugen. Geeignet zur Demontage und Montage einzelner Reifen sowie Zwillingsreifen. Sowohl Hand-als auch Pedalbedienung. Ausgestattet mit lenkbaren Rädern und Tragarmen mit doppelten, kugelgelagerten Rollen.

Zusätzliches Neigen des Lifts möglich, um das genaue Zentrieren des Rades zu erleichtern.

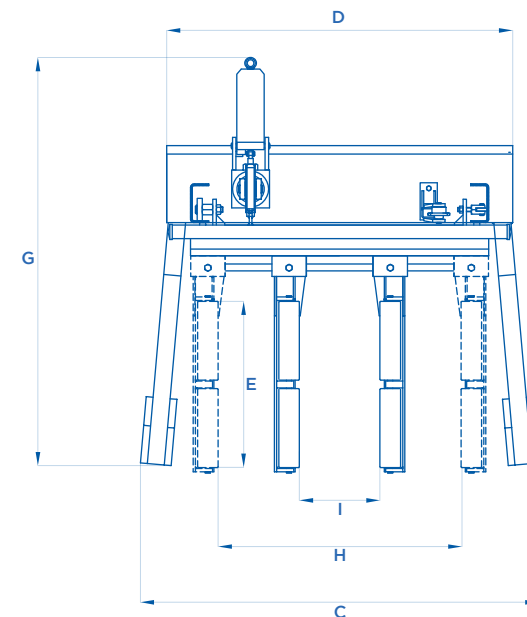
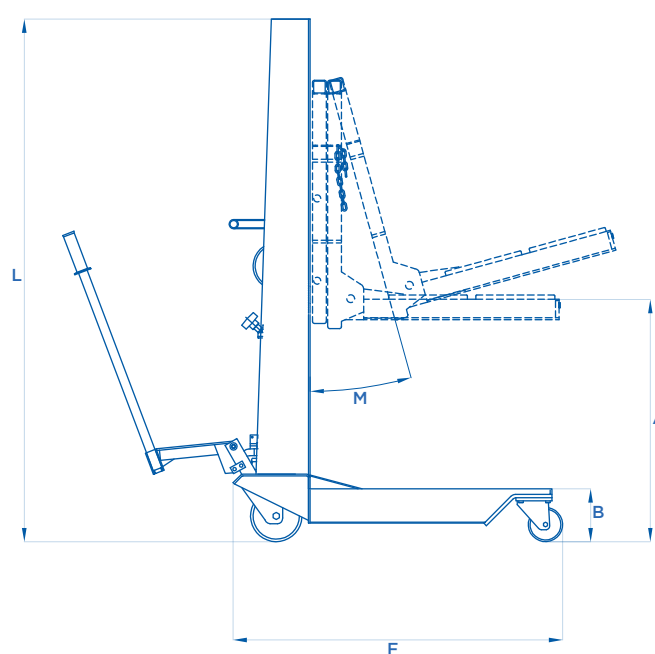

ART. 227/B

ART.		A mm	B mm	C mm	D mm	E mm	F mm	G mm	H mm	I mm	L mm	M α
227/B	700 kg	920	160	1170	1010	490	930	1180	670	410	1445	10°